

**SKL 863 Terex Loader  
with electric condenser  
Installation Instructions**



1-800-267-2665  
1-888-267-3745 (FAX)

**Evaporator:** The evaporator setup for the Terex loader is a “drop in” design that goes in under the operators seat. It uses the original heater blowers, air ducts, louvers, blower controls and air filters with some minor modifications to reduce the outside air intake.

Steps:

1. Unbolt the seat plate from the seat platform. Leave the seat attached to the plate. Slide the seat plate forward towards the steering wheel to expose the blowers and foam piece that covers the top of the heater box. Remove the foam piece and put aside for later re-installation.

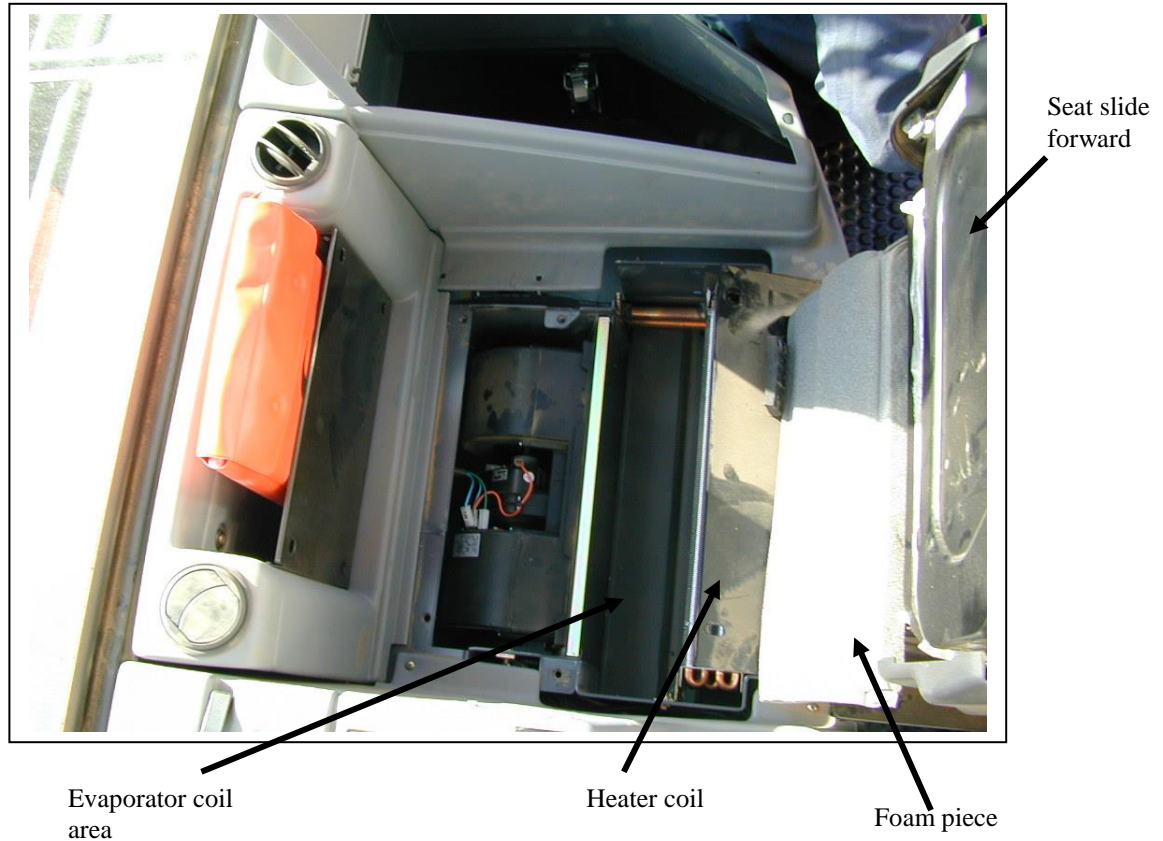

2. Open the storage compartment to the right of the operators seat. Remove the contents of the compartment. Remove the rubber mat on the bottom of the compartment.
3. Remove the triangular shaped cover plate from the left hand wall of the storage compartment. Remove the four M8 nuts that hold the cover plate to the left wall and rear wall of the compartment. Remove the two philps screws from the plastic storage compartment cover that screw into the cover plate on the heater box side of the storage compartment. Slide the cover plate out to the right and remove it from the storage compartment.

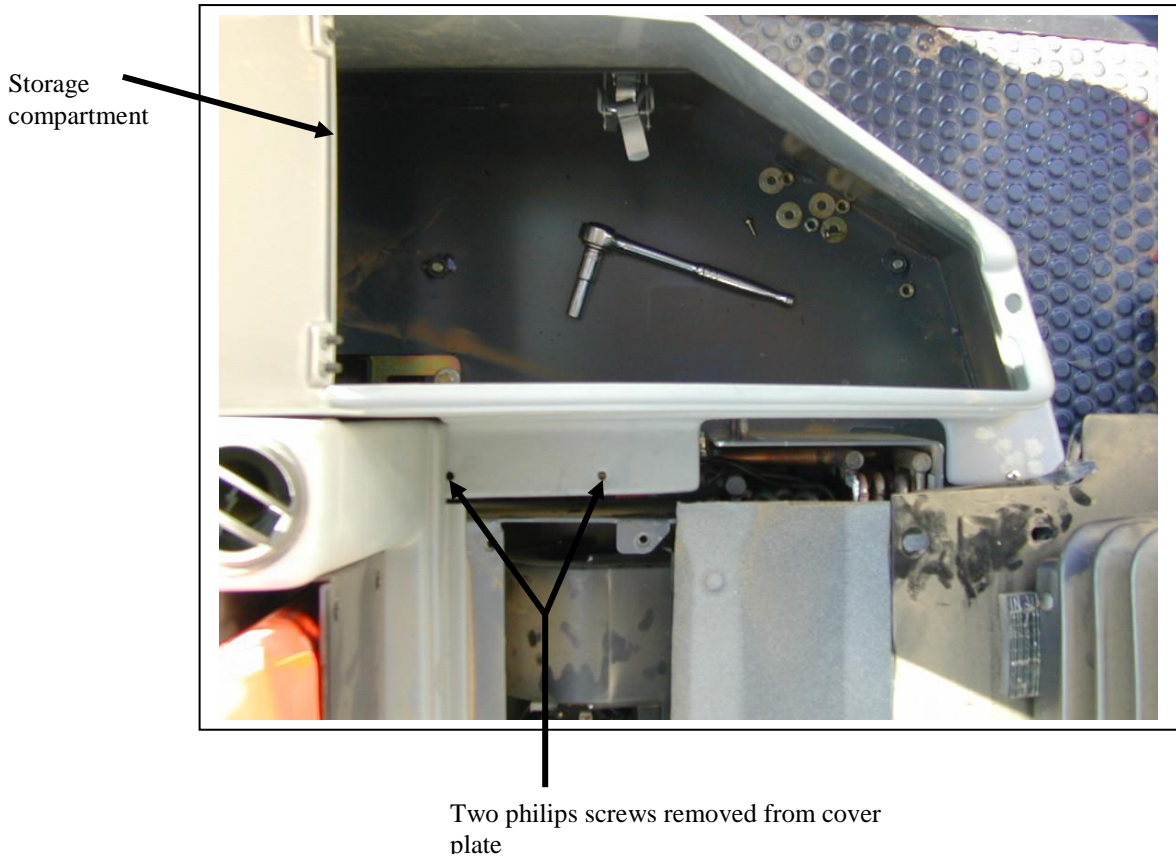
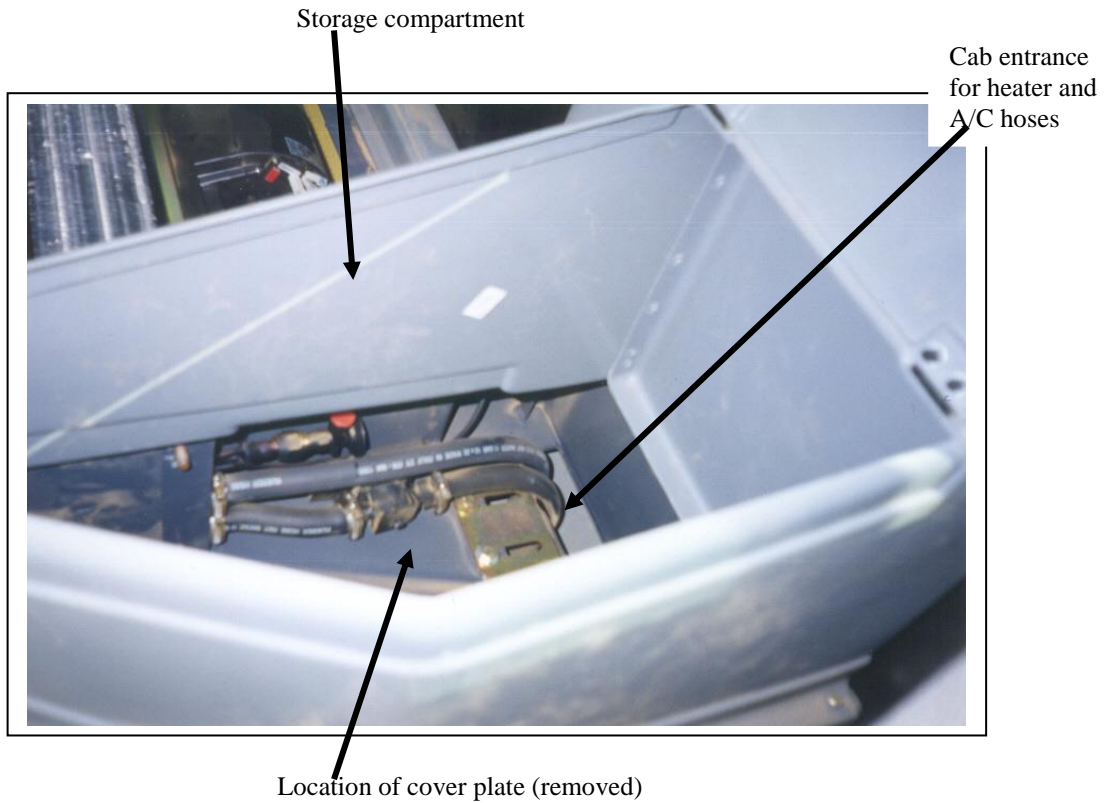

4. Remove the heater coil retaining bracket from the right hand side of the heater box. It sits between the heater coil and blowers and is held in place with two M6 bolts and nuts. Discard the bracket and hardware, it will not be reused.

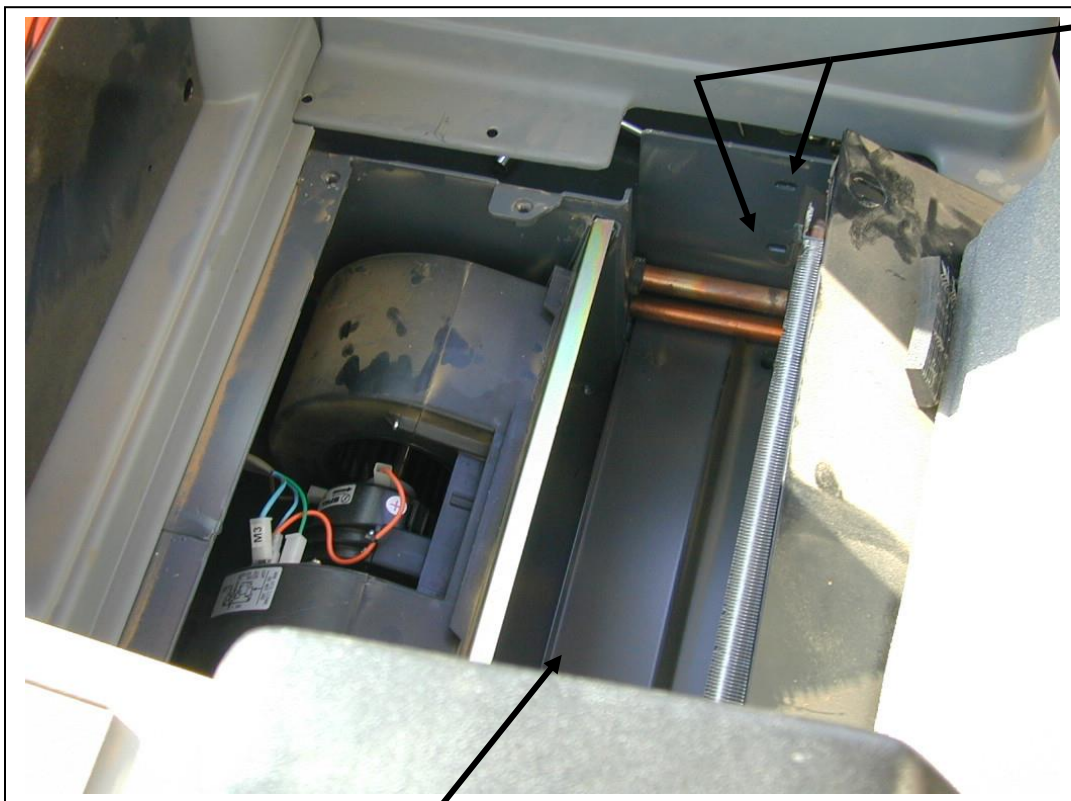

Holes from bolts holding the heater coil retaining bracket

Evaporator area

5. Slide the evaporator coil into place with the fittings on the right side pointing towards the back of the cab. On the left side of the evaporator coil, the front flange on the evaporator coil should be in between the heater coil flange and the coil retaining bracket.



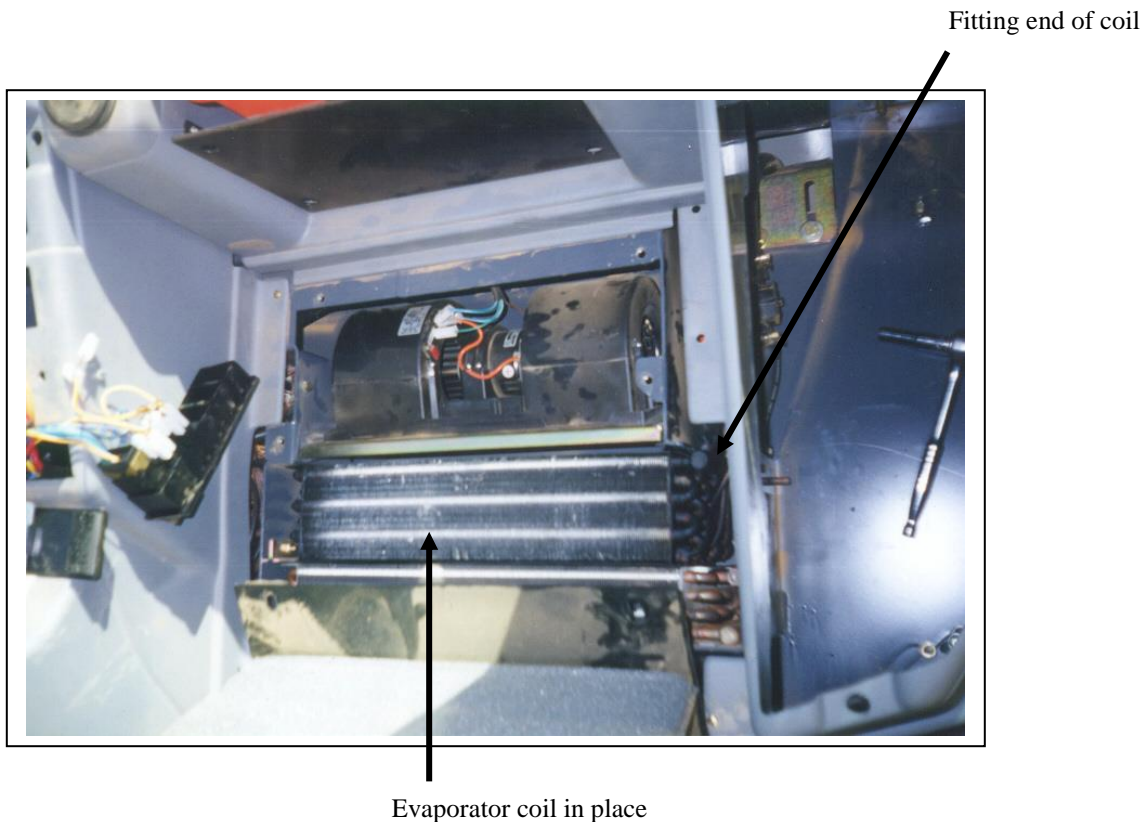

6. The evaporator coil should sit flush with the heater coil at the top.



7. The thermostat probe is run from the thermostats location on the left hand control console towards the back of the console and through the existing grommet for the blower wires. This grommet can be easily accessed by temporarily removing the blower assembly. This is done by pulling up on the blower assembly frame and sliding it out of its hole. Run the thermostat probe along the top of the evaporator and insert it five inches deep into the coil between the second and third rows of tubes from the front, about half way along the length of the coil.



Thermostat probe

Blower assembly removed

8. Using tar tape, seal the area all around the heater and A/C lines as they exit the heater box area. Also plug the two small holes left from the removal of the M6 bolts holding the right heater coil retaining bracket.
9. When the system has been all assembled and tested the foam pieces can be placed back on top of the heater and evaporator coils and the seat plate can be re-assembled. Also use tar tape to seat the hose inlet area into the cab and then re-install the triangular cover plate. Replace all the other items into the storage compartment.

Seal the heater and A/C lines to eliminate air leakage out of the box

Foam piece back in place

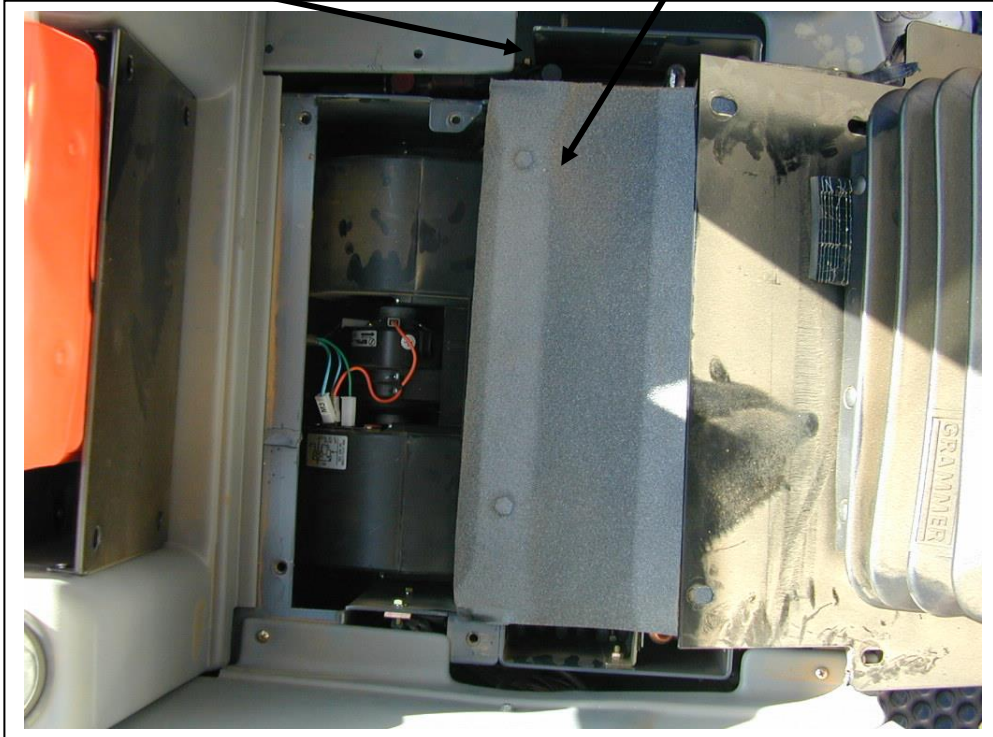

10. The outside filtered air intake for the cab is not designed for extreme climates and needs to be restricted to achieve the maximum cooling potential. This is done by removing the outside air intake panel on the right side of the cab, just behind the right door. On the back side of the air intake panel install the 6.5" X 6.5" piece of self adhesive foam so that it covers all but the bottom two louvered vents.

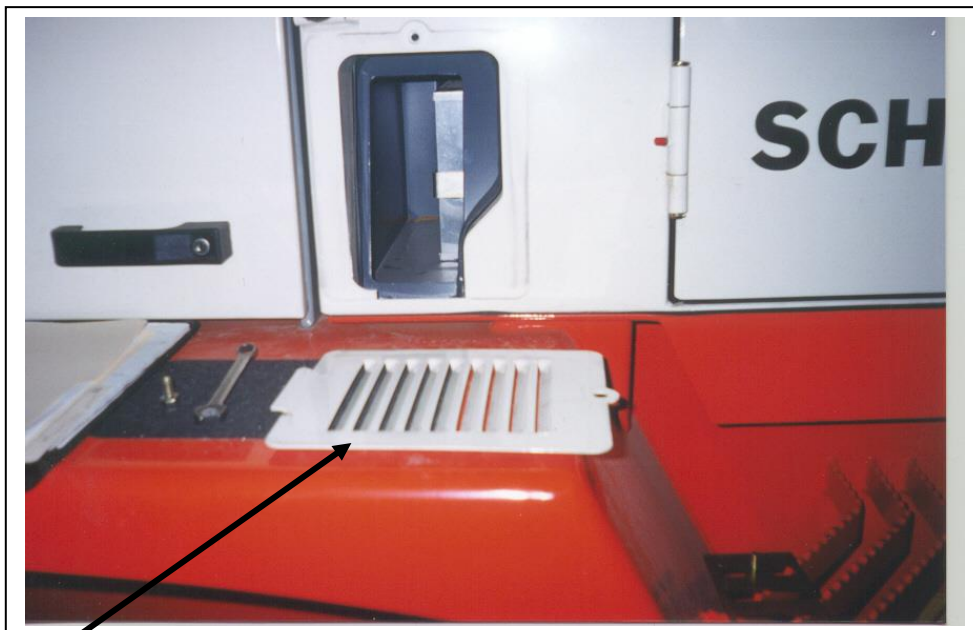

Air intake panel removed



Outside air filter

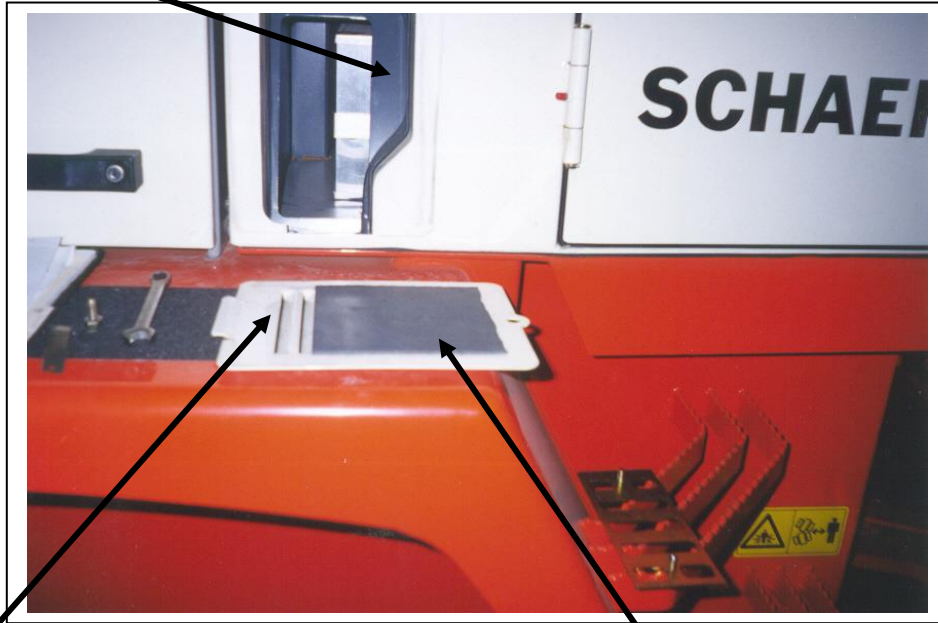

Two vents left open

6.5" x 6.5" foam installed

11. While the outside air intake panel is off, the slider plate to control this inside air re-circulation louvers can be removed. This slider plate is located on the lower right side of the right control console, just inside the right side door. Remove the two fasteners holding the slider plate on and let the plate fall down inside the air passage. Remove the slider plate from inside the cab by removing the filter and reach in behind it. By removing the slider plate, the inside air re-circulation cannot be accidentally shut off.

Inside air re-circulation intake vent



12. Replace the filter and outside air intake panel.



**Compressor mount:** The compressor is located on the top, rear, left hand end of the engine. The compressor drives off an add on pulley on the fan hub.

Steps:

1. It is necessary to adjust the angle of the top fitting on the top rear oil cooler hose. Loosen the fitting a little and rotate the 90° fitting up and towards the rear of the machine to make enough room for the compressor clutch.

The heater line must be relocated from the side of the thermostat housing to the inside port on the water pump housing above the injector pump. Drain the radiator fluid from the machine. Remove the 45° fitting from the coupler on the thermostat housing. Remove the coupler from the thermostat housing. Remove the inside ½” NPT plug from the inside port on the water pump housing. Retain this plug and re-install it in the empty ½” NPT hole on the side of the thermostat housing. Use new thread sealer on the plug. Re-install the coupler fitting into the open ½” NPT hole on the water pump housing. Use new thread sealer on the plug. Re-connect the 45° fitting on the heater line to the coupler. This fitting should be pointing to the right side of the machine and the heater hose should be run down beside the injector pump.

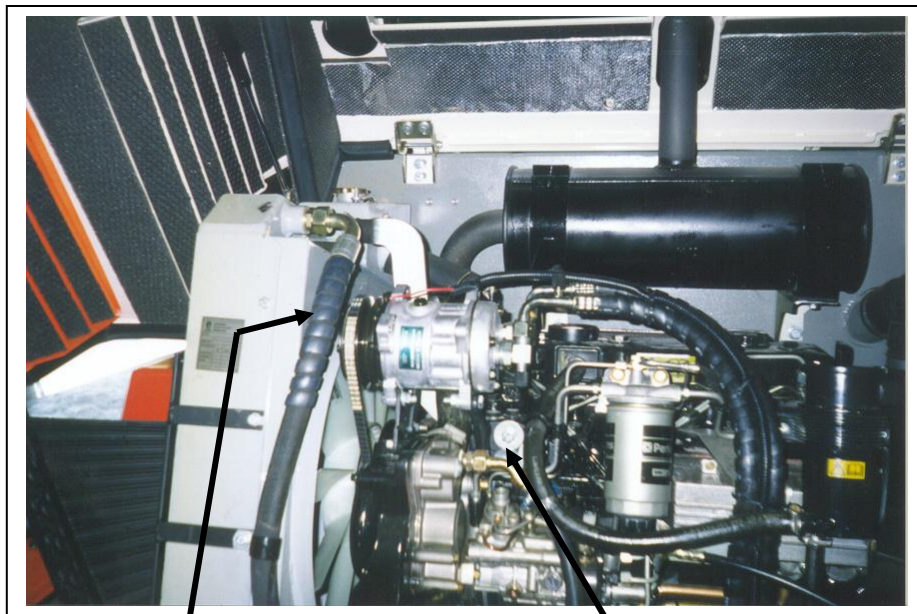

Oil cooler hose  
loosened and  
moved up and out

Original location of  
engine lifting bracket

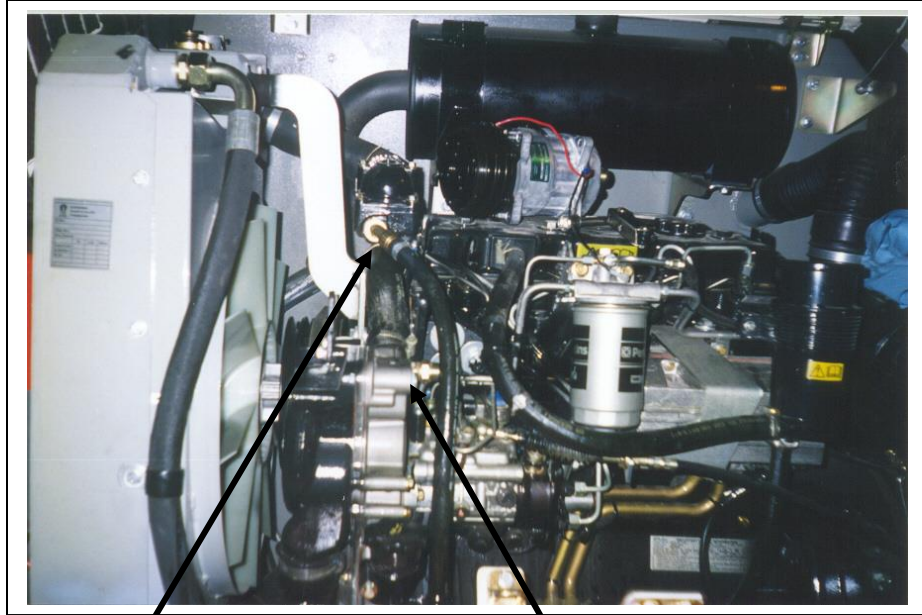

Existing heater hose location

Coupler installed in 1/2" NPT hole

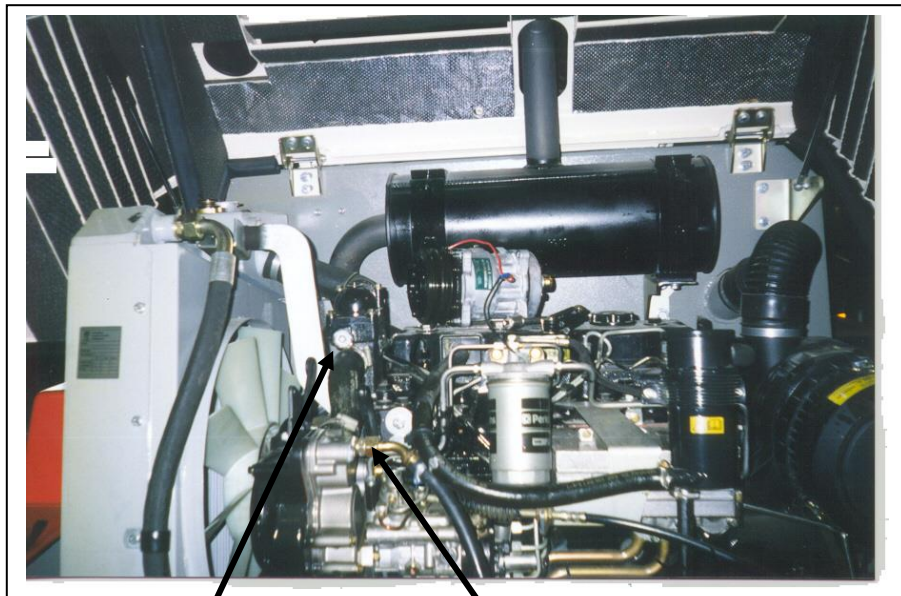

1/2" NPT Plug

New heater hose location

2. Install the add on pulley onto the fan hub before installing the compressor. Remove the fan blades by undoing the four self locking nuts from the studs on the fan hub. Set the fan ahead to the radiator coil inside the fan shroud. Unbolt the upper rad support bracket and push the complete rad assembly as far as possible to the left. This will allow enough room to remove and re-install parts onto the fan hub studs. Remove the existing fan spacer from the studs. Install the add on pulley onto the fan hub studs with the recessed side of the pulley towards the engine. Re-install the original fan spacer onto the studs and side it up to the add on pulley face. Install the extra 1/2" fan spacer supplied in the kit. Re-install the fan blades onto the studs and bolt back down using the original self locking nuts. Before bolting the fan back into position, it saves time to install the compressor drive belt around the add on pulley.

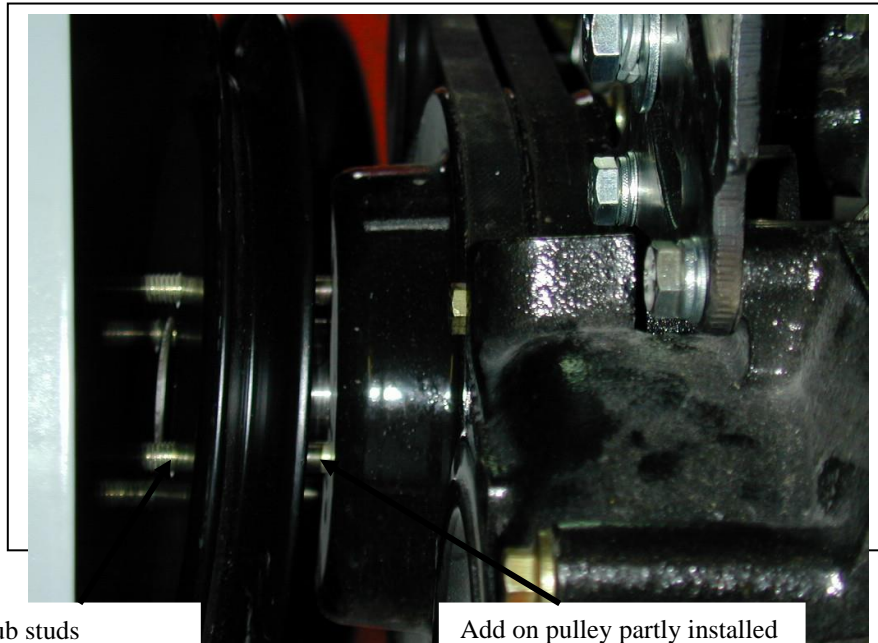

Fan hub studs

Add on pulley partly installed  
1 fan hub studs

Add on 1/2" fan spacer

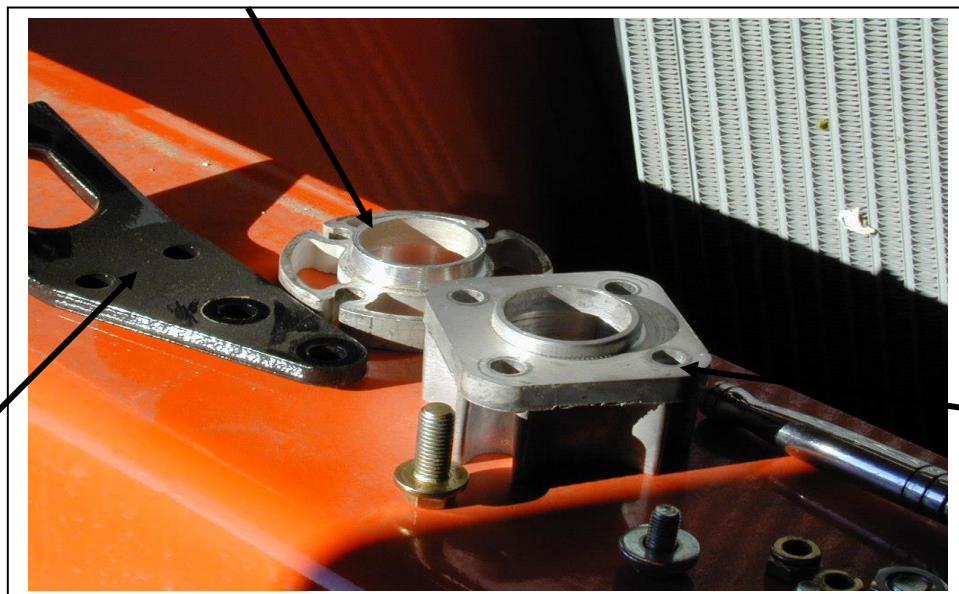

Engine lifting  
bracket

Original fan  
spacer



3. The compressor mount consists of three different brackets, the front bracket, the tightener arm and the rear bracket. Remove the engine lifting bracket from the engine. It is located to the right of the water pump housing and above the injector pump. Bolt the rear mount bracket (3 slotted mounting holes) onto the original engine lifting bracket location using the M10 x 35 mm hardware provided. It may be necessary to loosen the lower clamp on the coolant hose and rotate the clamp so the tightening screw doesn't hit the front of the rear compressor mount bracket. Leave the three bolts on the rear bracket loose until the compressor is installed and the alignment checked.

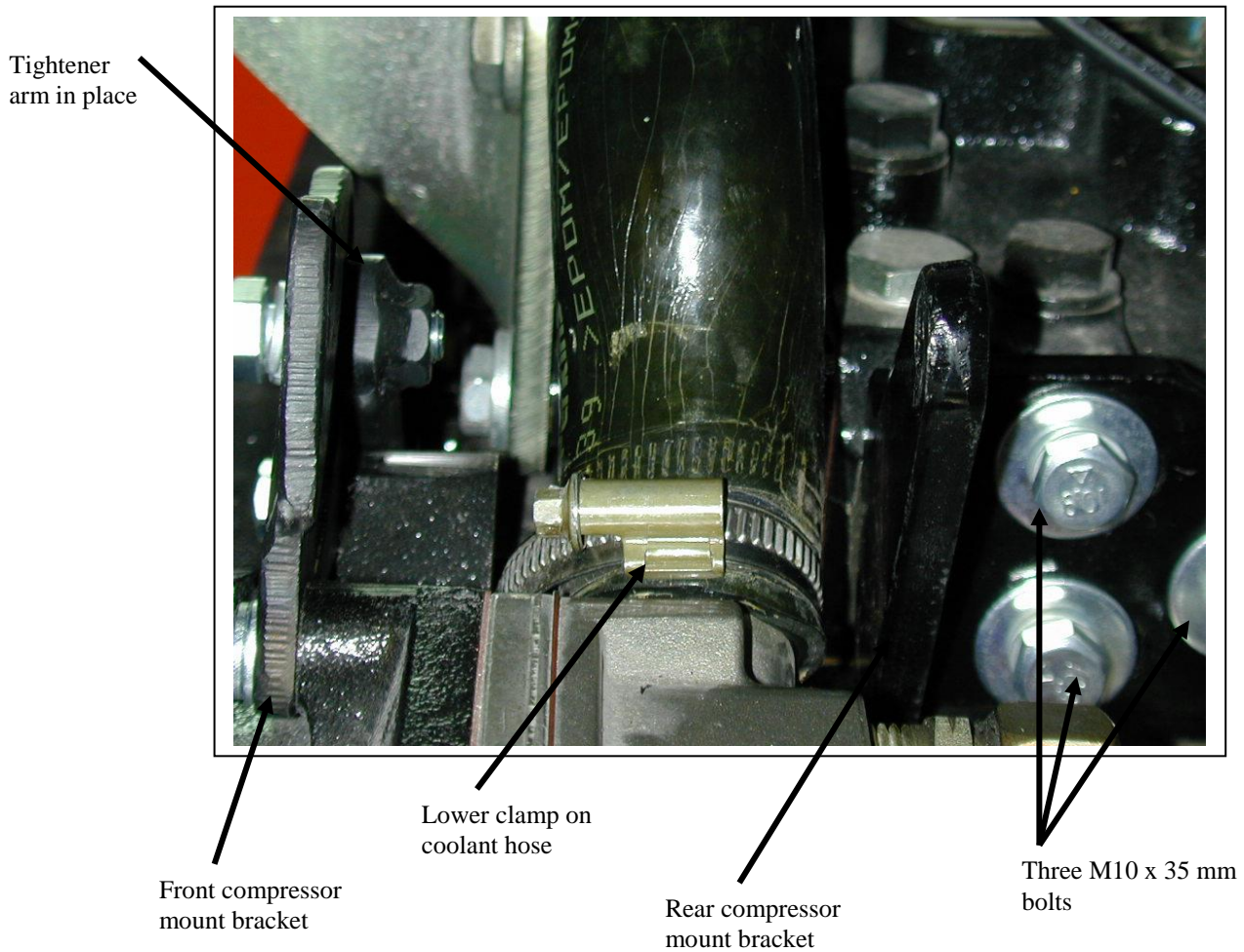



4. The front compressor mount bracket bolts to the water pump housing using the two M8 bolts. The M8 x 30 mm bolt provided is used to secure the inside bolt hole (below the long curved slot) to the open M8 threaded mount block on the engine side of the water pump housing. Remove the existing M8 bolt from the top of the water pump housing. Use the M8 x 65 mm bolt provided to secure the outside hole (below the offset triangular compressor mount hole) to the now open bolt hole. Tighten the bracket securely in place.

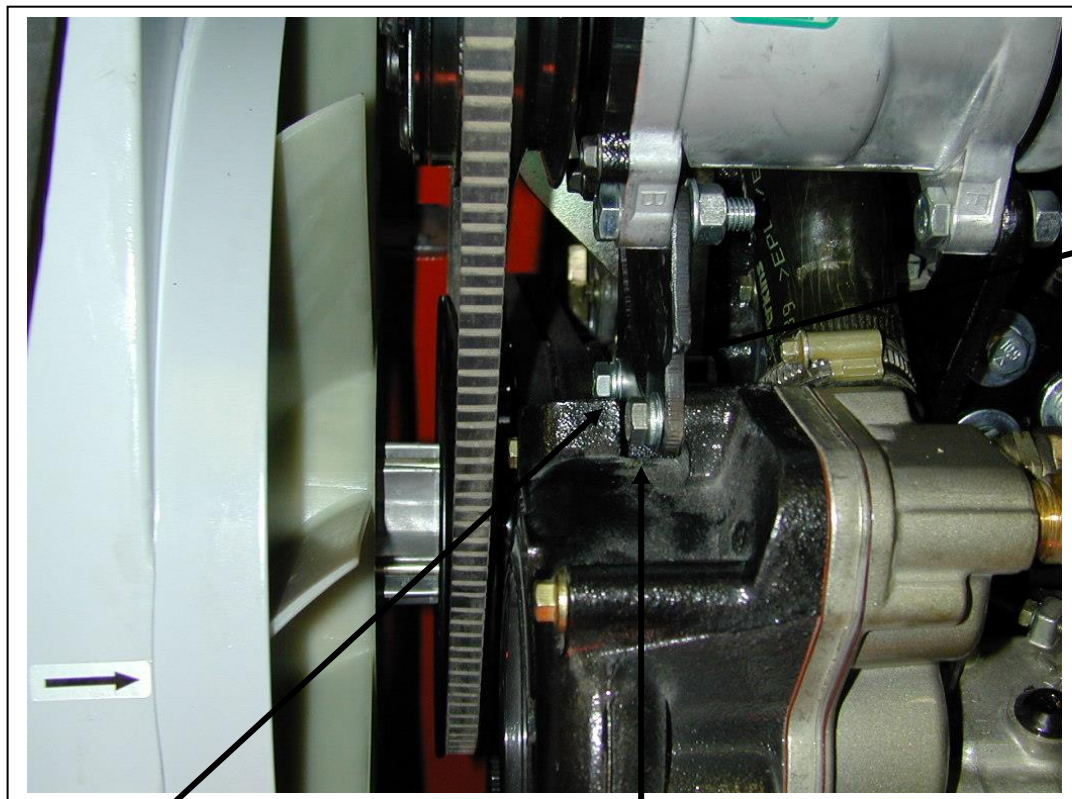

Front  
compressor  
mount  
bracket

M8 x 30 mm bolt in  
threaded mount block

M8 x 65 mm bolt in top of  
water pump housing

5. The compressor tightener arm gets bolted to the long curved slot on the front compressor mount. The end of the arm with the threaded M10 nut welded to it, is bolted to the right side of the curved slot using the M10 x 35 mm bolt provided. The arm should be just bolted loosely in place.

- Set the compressor onto the front and rear brackets with mount ear B of the compressor to the left side of the top rear hole on the front bracket. Use a M10 x 40 mm bolt to secure the compressor are to the bracket. Bolt the corresponding are of the back of the compressor (ear F) to the front of the rear bracket. Use the other M10 x 40 mm bolt to secure the compressor ear to the bracket.

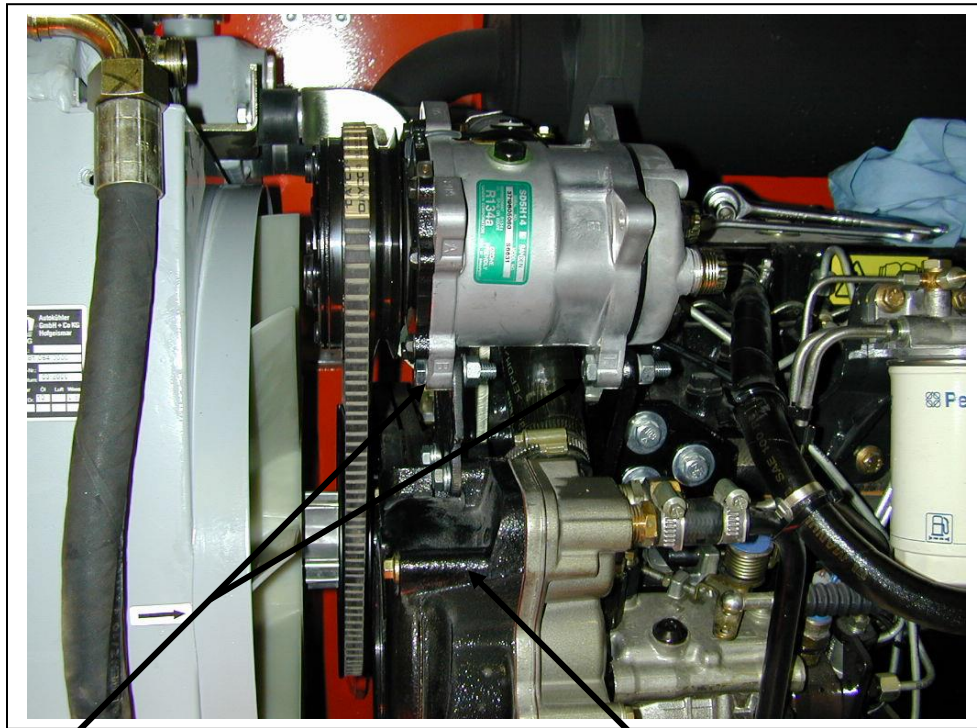

M10 x 40 mm bolts on ears  
B and F

Complete mount, pulley  
and drive belt

- Bolt the open end of the tightener arm to the right side of ear C on the compressor. Use the M10 x 45 mm bolt provided.
- Install the 17450 compressor bolt around the add on pulley on the fan hub and the front pulley groove on the compressor. Check the belt alignment using a straight edge across the add on pulley. Tension the drive belt by rotating the compressor up and back. Tighten all the bolts down on the mount to secure the compressor in place. Blue locktight is recommended for all bolts threading into the engine.

9. Install the rotolock fittings onto the fitting ports on the back of the compressor. Remove the caps from the compressor parts. Install the white nylon gaskets into the grooves on the ends of the fitting ports. Attach the 13/32" rotolock fitting onto the discharge port (closest to cab) marked "dis" or "D". Have the threads on the 13/32" rotolock pointing up and slightly towards the front of the machine. Attach the 1/2" rotolock fitting (large one) to the suction port marked "suc" or "S". Have the threads on the 1/2" rotolock pointing up and slightly toward the front of the machine. Oil all contact surfaces on the rotolock with PAG refrigerant oil.



Rotolocks and hoses installed on the compressor



## Condenser Installations

The electric condenser mounts behind the cab on the flat panel between the side access doors.

Steps:

- 1) Locate the flat metal panel directly behind the cab.
- 2) Mark and drill two 1 1/8" holes for the hose grommets in the 27" x 27 1/2" panel behind the cab. See the supplied drawing for the grommet positioning
- 3) Install the grommets supplied into the 1 1/8" holes.
- 4) Position the cardboard hole template onto the flat metal panel behind the cab, using the supplied drawing for exact positioning. Double check that the four mount holes will pass through the "C" channel on the underside of the flat metal panel.

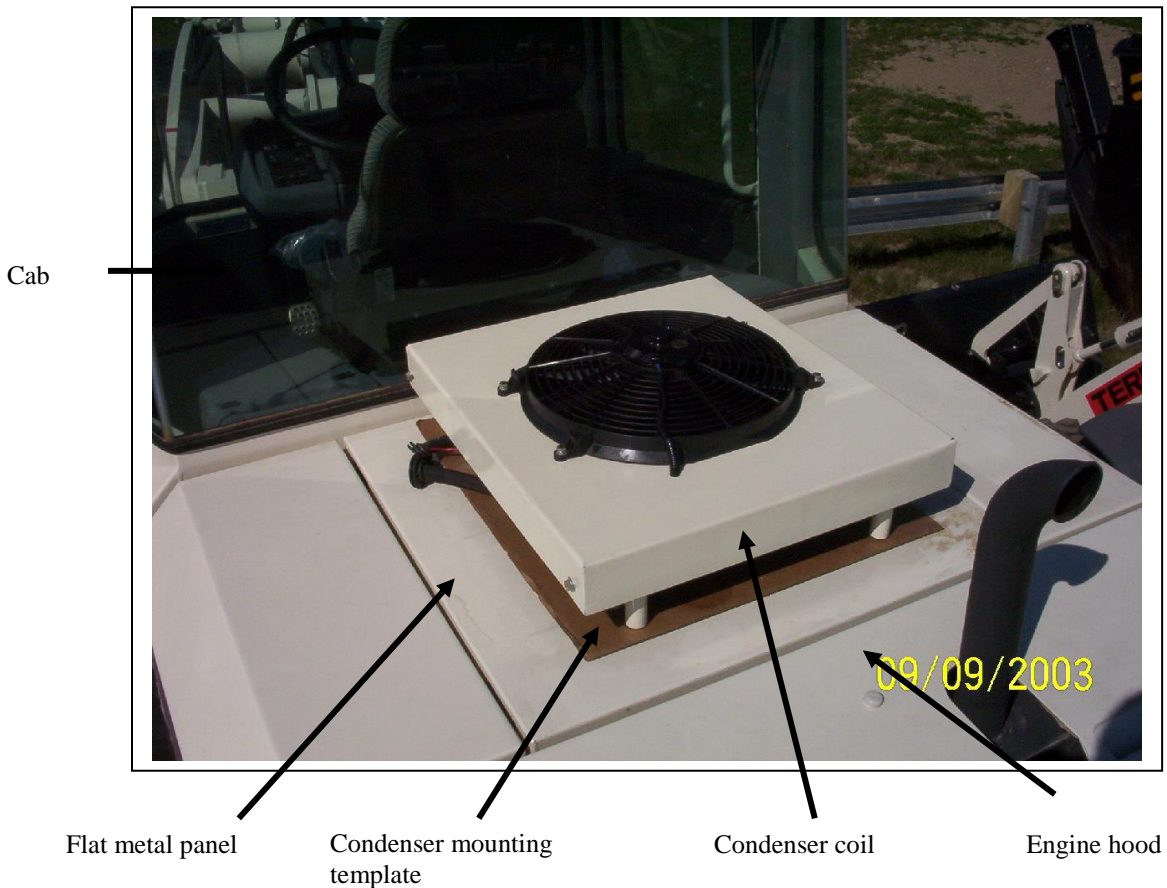

- 5) Mark and drill the holes to 3/8", passing through the top plate and the "C" channel.



## 863 CONDENSER PLACEMENT

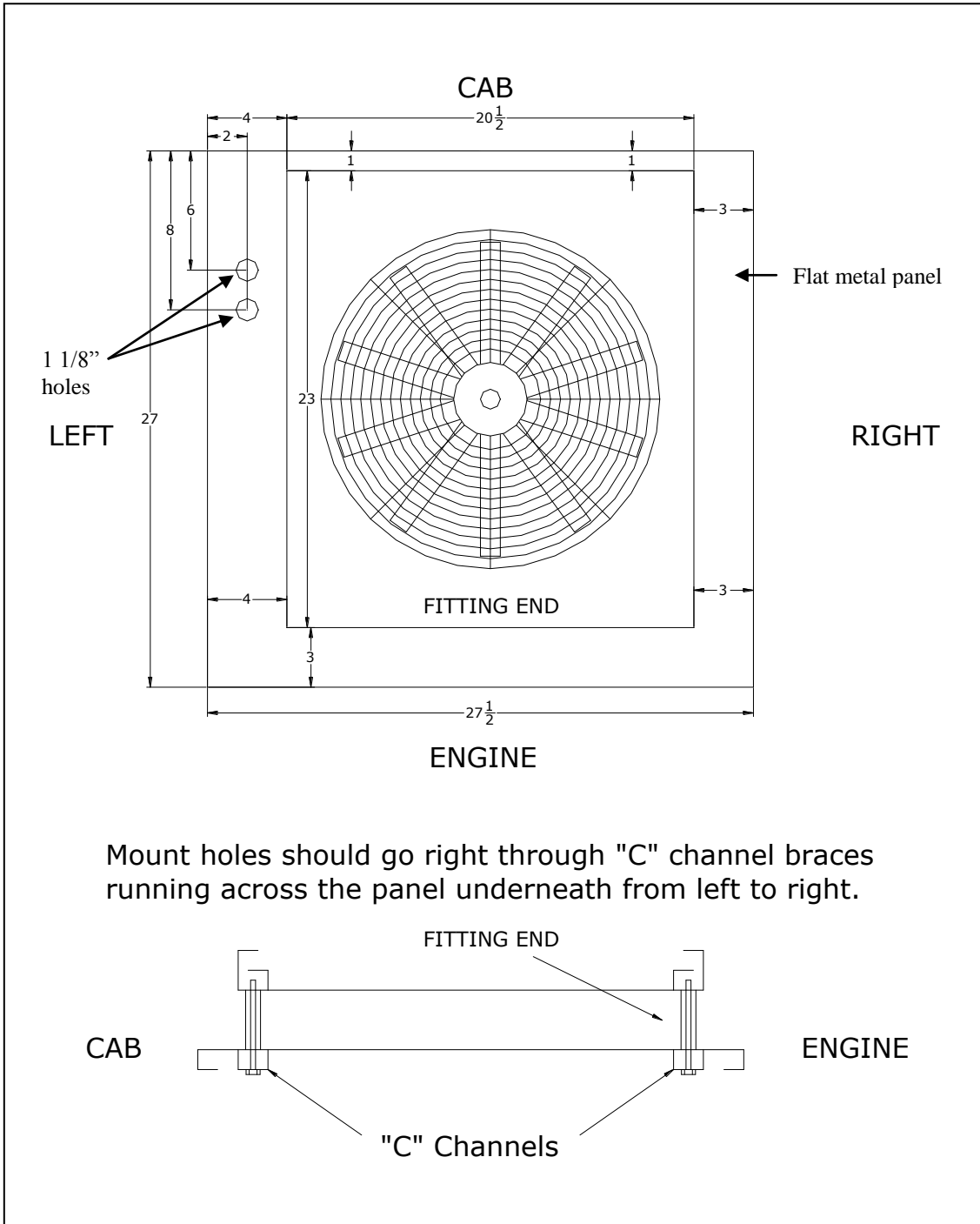

- 6) Place the condenser over the mount holes but don't bolt it down until the hoses are connected. Ensure that the condenser fittings are towards the back of the machine.
- 7) Run the 5/16" hose from the inlet side of the drier to the condenser. Run the straight fitting end of the hose up through the grommet closest to the cab. Run it under the condenser and over to the 5/16" fitting on the back right of the condenser. Connect the hose to the condenser.

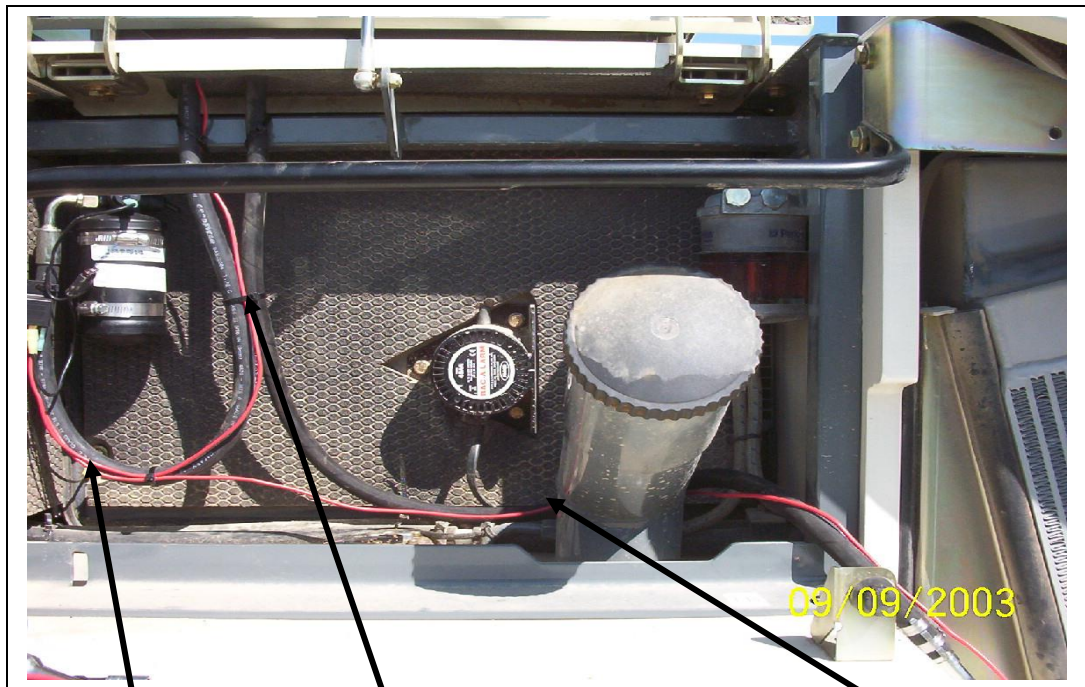

5/16" hose routed up through the grommet to the condenser.

Hoses and condenser power wire going up through grommets

13/32" hose route



5/16" hose connected to condenser on back right hand side. The condenser may have to be lifted up to gain access for the wrenches.

- 8) Run the 13/32" hose up through the second grommet and back to the 13/32" fitting on the left rear corner of the condenser. Connect the 13/32" straight fitting to the condenser. **\*\*NOTE\*\*** Use the proper sized "O" ring on all hose connections and oil all "O" ring connections with PAG oil before installing.



5/16" hose up through grommet

Condenser power wire

13/32" hose up through grommet

9) When both hoses are connected to the condenser, it may be permanently bolted in place.





**Drier installation:** The drier is located just behind the cab, on the left side of the machine, inside the fuel compartment on the back wall.

Steps:

1. Remove the M8 bolt from the front, top, inside corner of the fuel fill compartment (above and forward of the alarm)
2. Bolt the 90° offset drier bracket to the same hole using the M8 x 60 mm hardware and 1 ¼" spacer provided.
3. Clamp the drier to the drier bracket using the two #48 gear clamps provided. Have the inlet side of the drier pointing towards the front of the machine and a little out to the left.

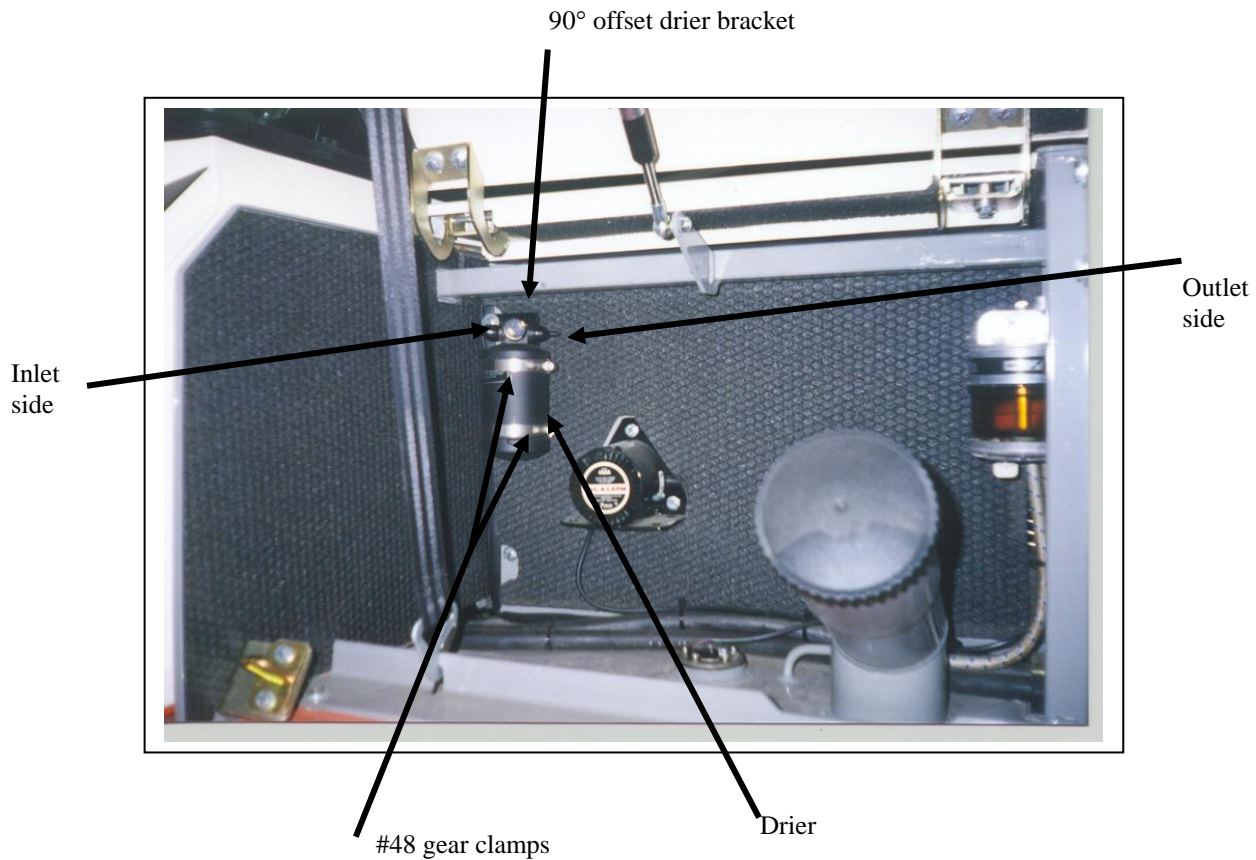

**Electrical:** The electrical system for the A/C is very straight forward. Power is taken from the blower switch wiring, over to the thermostat and then out of the cab through a hole in the bottom of the right hand console. From there it is routed over to the A/C hoses and back to the relay located at the drier

Steps:

1. Remove the rubber plug just to the left of the heater control lever. File the hole out enough to allow the threaded stem on the thermostat to fit through.
2. Remove the switch panel containing the blower switch from the console.
3. Splice into the wire coming off the blower switch that has full volt power when the switch is set on any of its speeds. This should be the light blue wire. Splice into the wire using the in line ATO fuse holder. Connect the other end of the fuse holder to the thermostat. Install the 3 amp ATO fuse into its holder.

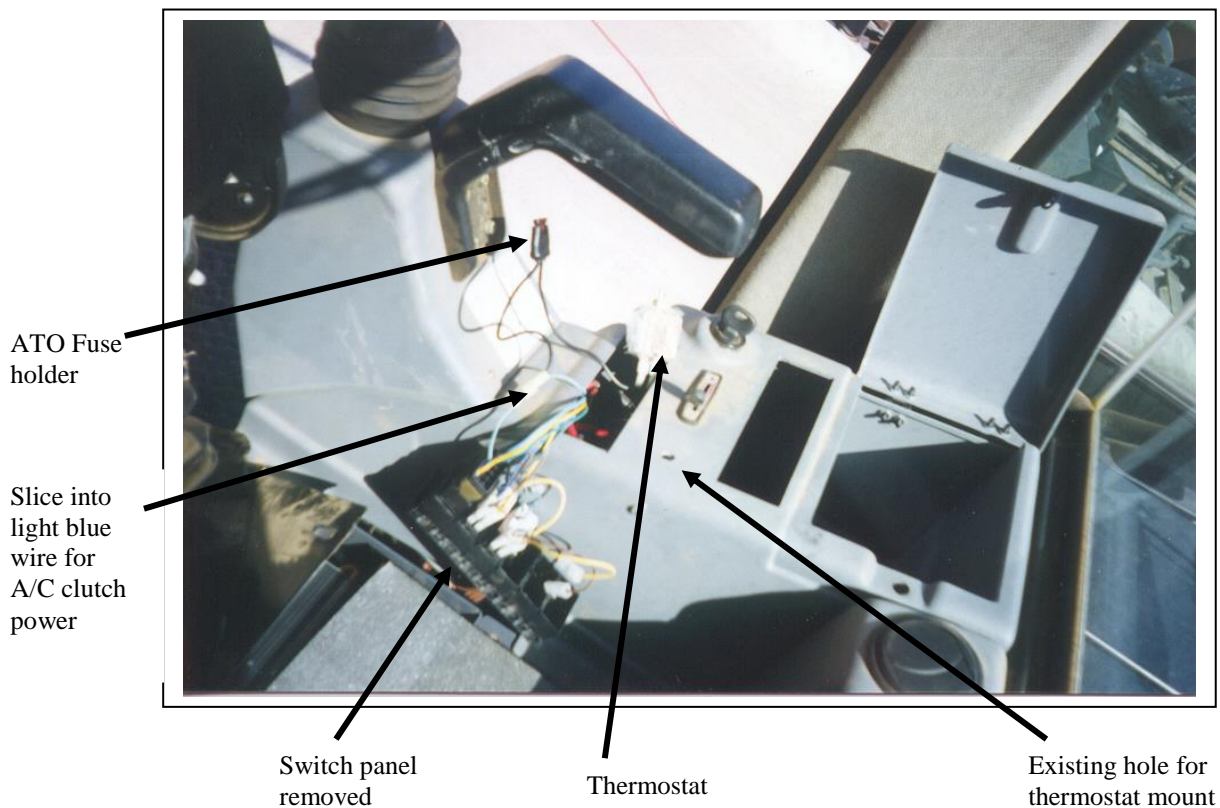

4. From under the cab, run the 14 gauge black wire in loom up into the right hand console and connect it to the other terminal on the thermostat. Run the thermostat probe as explained in the evaporator installation instructions.
5. Once the system has been tested and any adjustments made, the thermostat can be installed in the enlarged hole to the left of the heater control lever. Install the thermostat decal and knob as well.

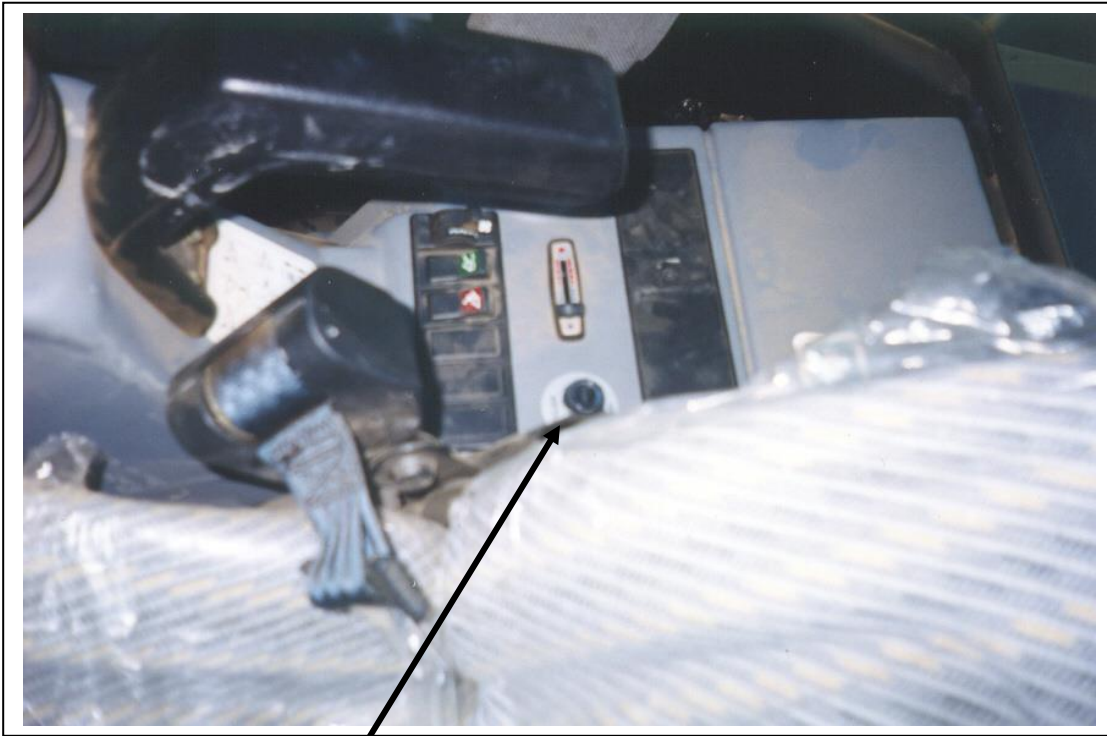

Thermostat installed

6. Complete the running of the 14 gauge black wire from underneath the cab to the drier by routing it along with the A/C hoses.
7. Mount the supplied relay and wiring harness to the 5/16" inlet hose just below the fitting. Use a tie wrap to hold the relay.
8. Connect the ground wire to the M8 bolt on the lower left of the panel the drier is mounted on.
9. Plug the compressor clutch wire coming from the cab to the open side terminal on the relay.( see electrical drawing)



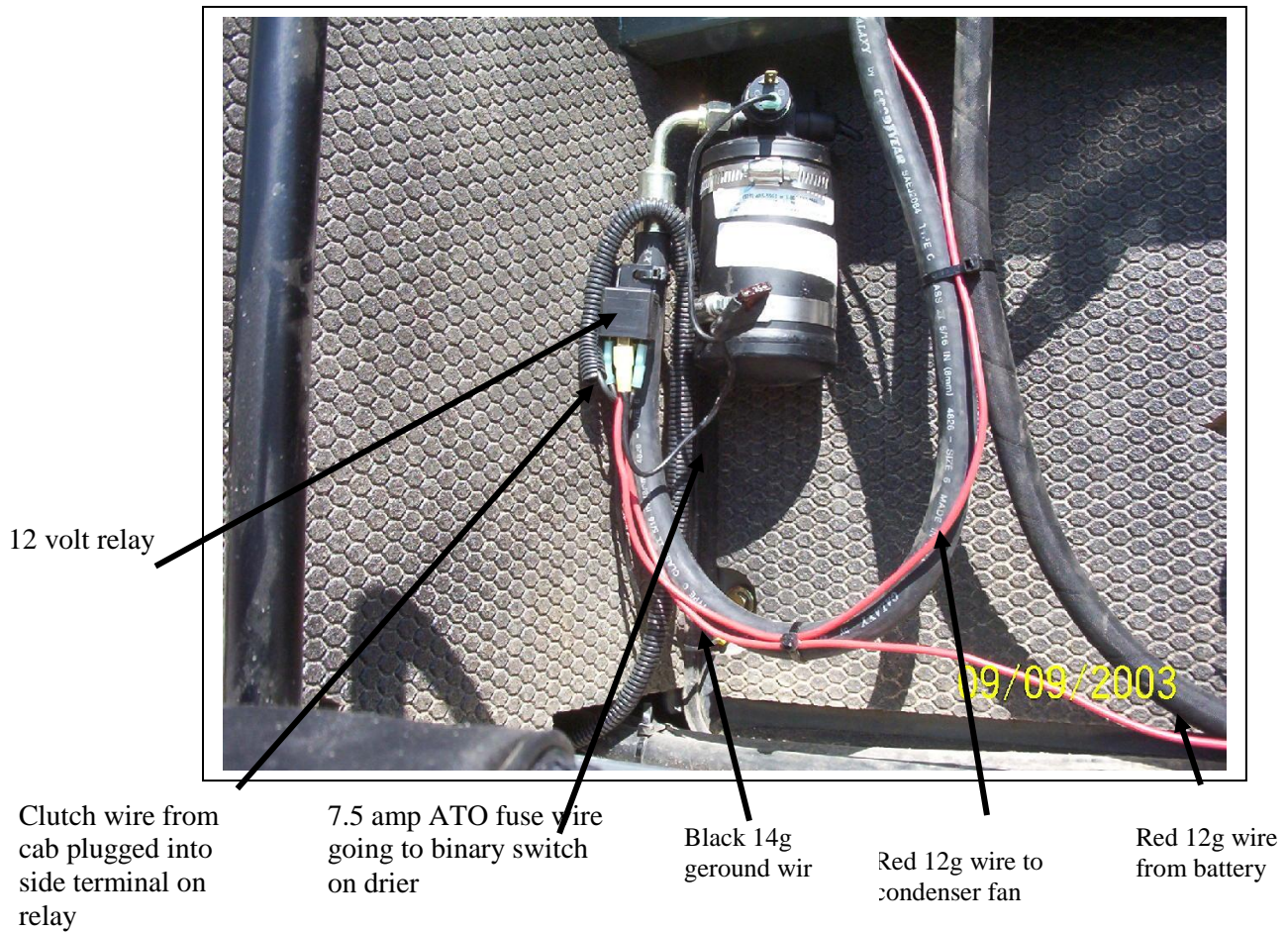

10. Plug the black wire with the 7.5 amp ATO fuse in it to the open terminal on the binary switch.
11. Run the 12g red wire that is 37" long (coming off the same terminal as the 7.5 amp fuse wire), up through one of the hose grommets and plug it into the power wire for the condenser fan.



Wire connection at condenser for condenser fan power

12. Run the 12g red wire that is 73" long (with the 15 amp ATO fuse at the end), down along with the 13/32" A/C hose to the battery. Bolt the ring terminal on the end of the wire to the positive battery terminal as shown in the pictures.



25 amp ATO fuse

Ring connector on positive battery terminal





12g red wire running to relay  
(will be in wire loom)

Fuse holder secured to  
battery cable

Positive terminal cover back in  
place

13. From the other terminal on the binary switch on the drier, run the 14g black wire in loom along with the A/C hoses to the compressor. Connect the clutch wire coming off the compressor to the 14g black wire.
14. Secure all hoses and wiring using the tie wraps provided.
15. Run the A/C system to test it. Ensure that the condenser fan is running whenever the A/C compressor is engaged. (i.e.. clutch is pulled in.)



# SKL 863Electrical

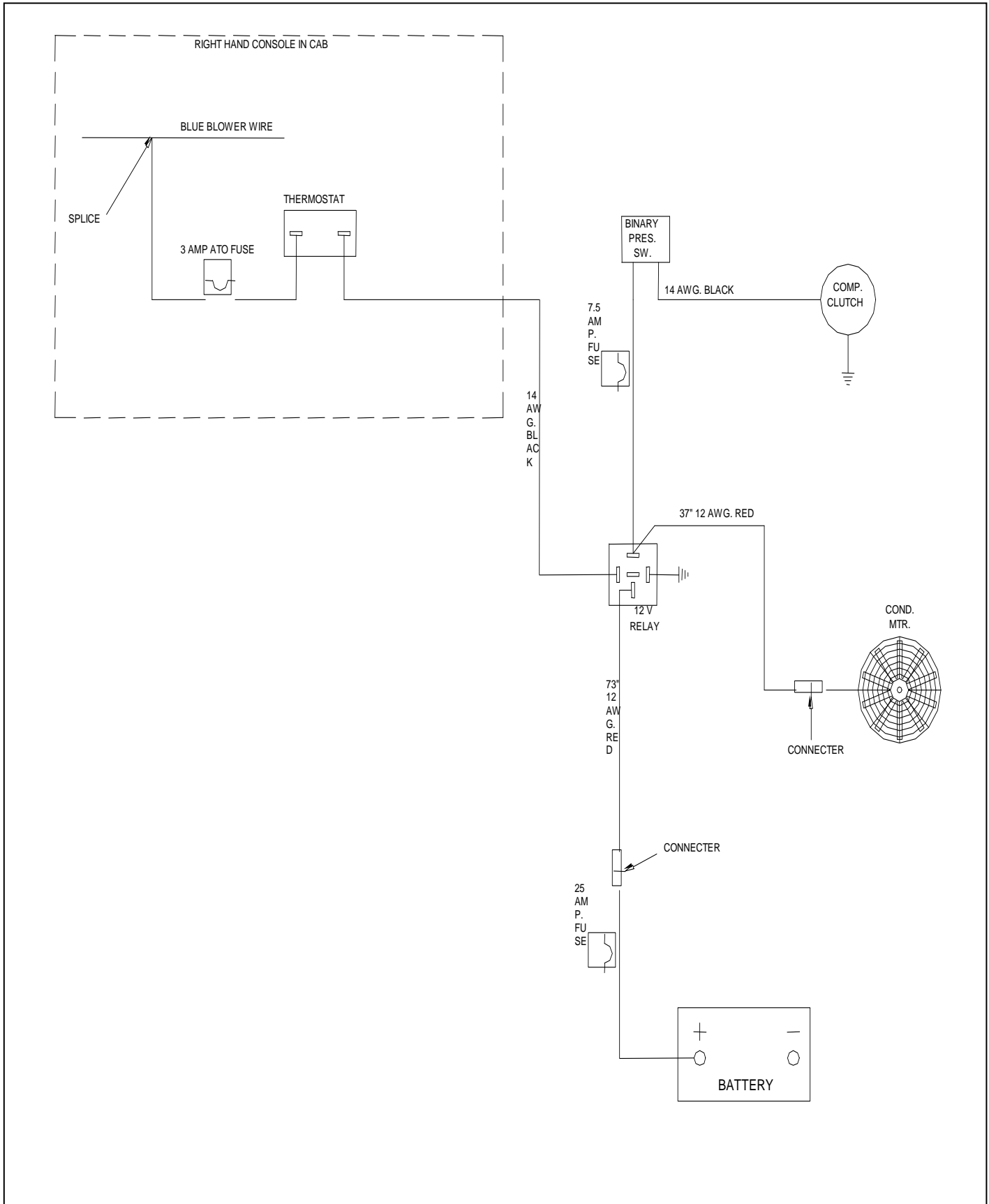

**Hose Runs:** The A/C hoses connect all the major components of the system together. They are all pre-cut and crimped. All fittings require the proper sized “O” ring to be installed on them and all contact surfaces need to be lightly oiled with refrigerant oil before final assembly on the machine.

Steps:

1. Starting at the compressor, the ½” hose connects to the ½” rotolock fitting on the compressor with a 90° female fitting complete with access port. Loop the hose towards the right side of the machine and down the back side of the engine. Route the ½” hose back to the left side of the machine, beside the bottom of the engine and under the radiator into the battery area. The air dam that blocks the area below the radiator must be removed and notched out to fit the two A/C hoses and the clutch wire. Once both hoses are run, re-install the air dam and seal any air gaps with tar tape.

Run the ½” hose along the bottom of the radiator, beside the battery cables and up the cab side of the radiator. Continue the ½” hose up and forwards, under the fuel fill spout and into the cab beside the heater hoses. Connect the ½” straight fitting on the hose to the male outlet fitting on the evaporator coil.

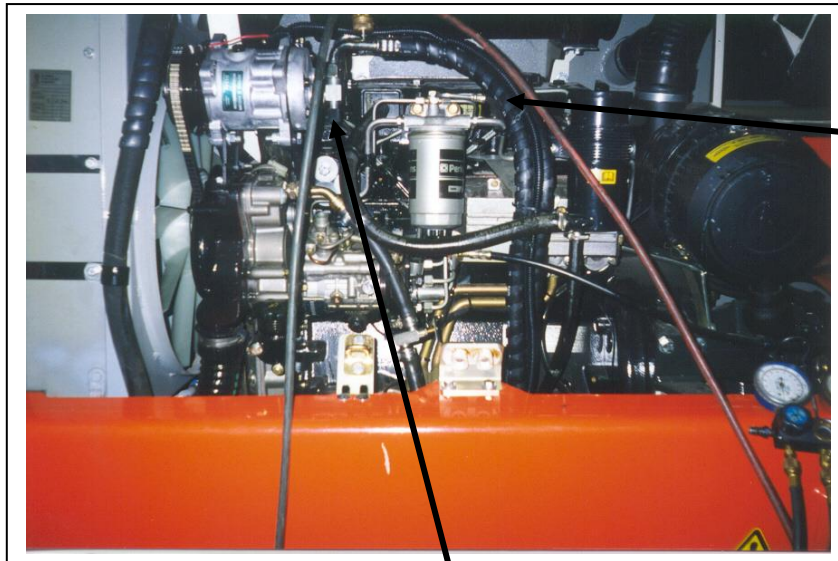

½” and 13/32”  
hose and clutch  
wire

½” rotolock and ½” hose

- Starting at the compressor, the 13/32" hose connects to the 13/32" rotolock fitting on the compressor (closest to cab). The 90° female fitting with the R134a port goes on the 13/32" rotolock fitting and is run along the same route as the 1/2" hose. The 13/32" hose follows the 1/2" hose along the bottom of the radiator and up the cab side of the radiator. It then runs over towards the drier and up to the electric condenser through the grommet closest to the engine. Connect the straight 13/32" fitting to the condenser 13/32" fitting on the left rear corner of the condenser..

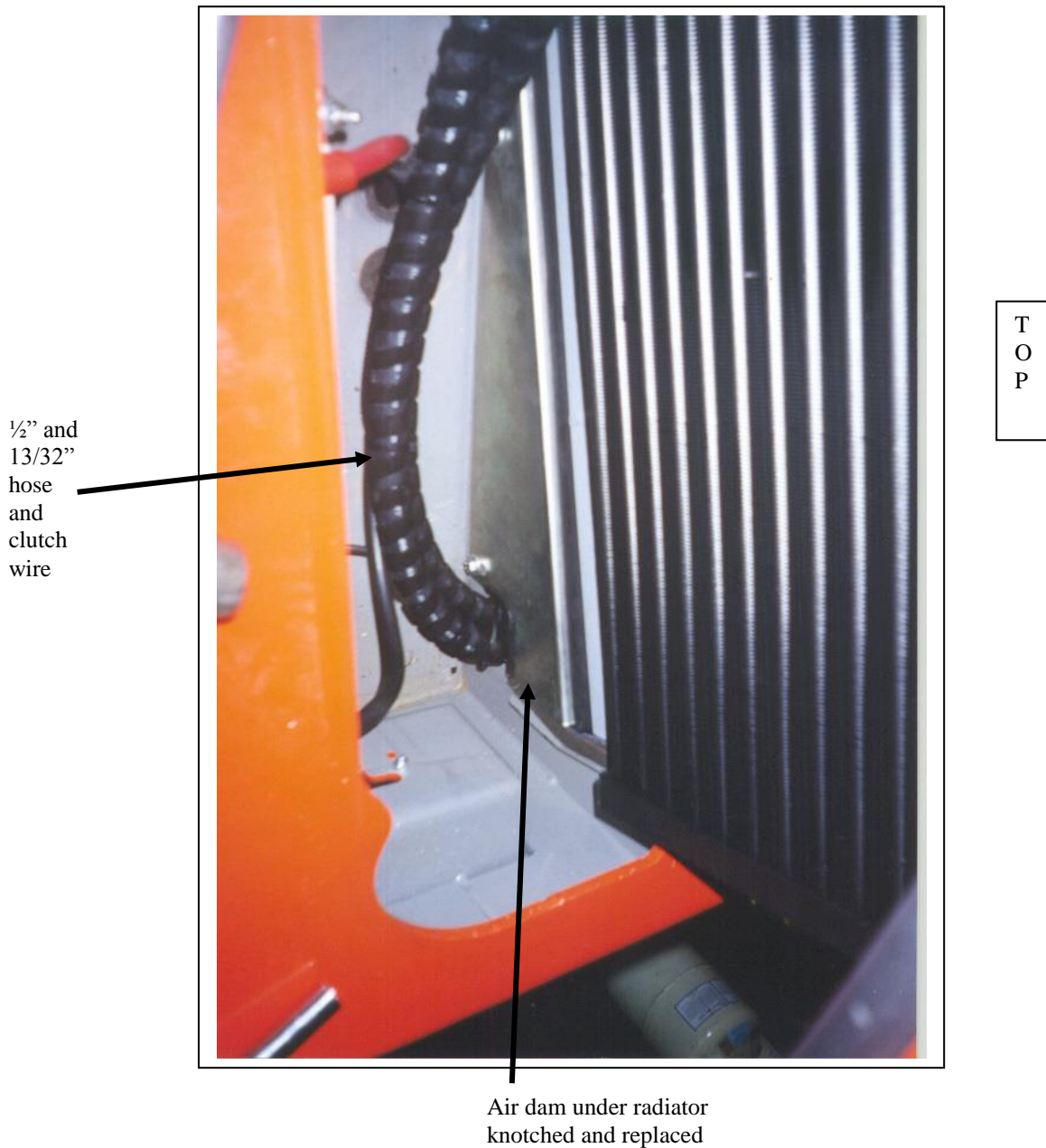

- At the right hand fitting on the condenser connect the 5/16" straight female fitting on the 46" long 5/16" hose. Run the hose under the condenser and then through the front grommet and down with the 13/32" hose to the drier. Connect the 5/16" 90° female fitting on the 5/16" hose to the inlet side of the drier (marked "IN").

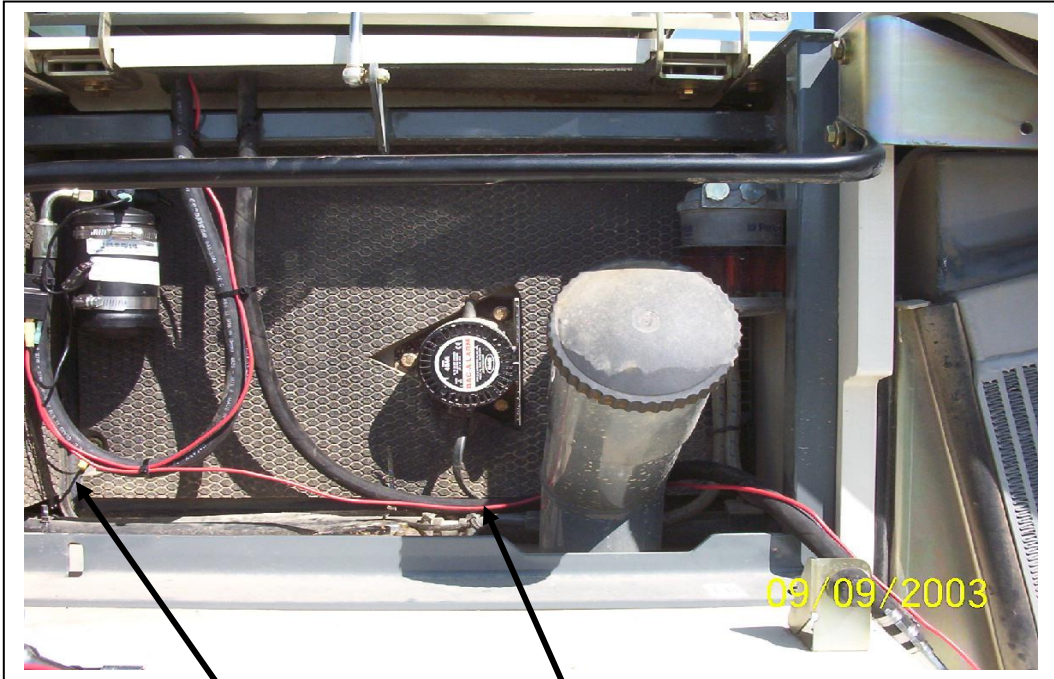

Location of hoses entering the cab      13/32" hoses and 1/2" hoses

4. Connect the 90° 5/16" female fitting to the outlet of the drier and run it down and forward to the bottom of the cab where the heater lines enter the cab. Bring the 5/16" line up into the cab and connect it to the expansion valve on the evaporator coil.

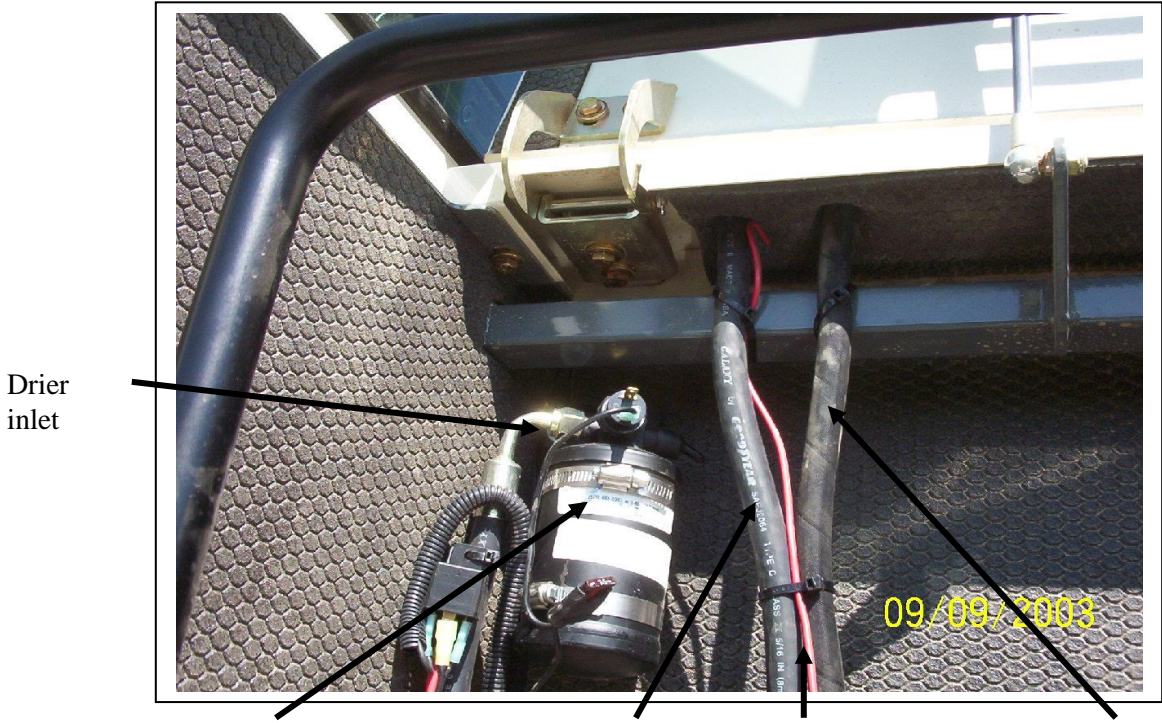

Drier inlet      Receiver drier      5/16" hose      Condenser power wire      13/32" hose



5. Using tar tape, seal all the air gaps around the evaporator line into the evaporator/heater area and around all the lines exiting the cab. Secure all hoses and wiring using the tie wraps provided. Protect hoses from chaffing and rubbing using the hose wrap provided. Make sure the hoses are well secured close to all the fittings to reduce stress on the connections.
6. On many machines, the factory heater control valve does not close very tight and will leak a small amount of radiator fluid past the valve. This can greatly reduce the cooling performance of the A/C system. To solve this problem a heater line shut-off tap has been included on the kit. It should be installed in an easily accessible area of one of the heater lines.

## Refrigerant Flow Pattern in a Standard Air Conditioning System

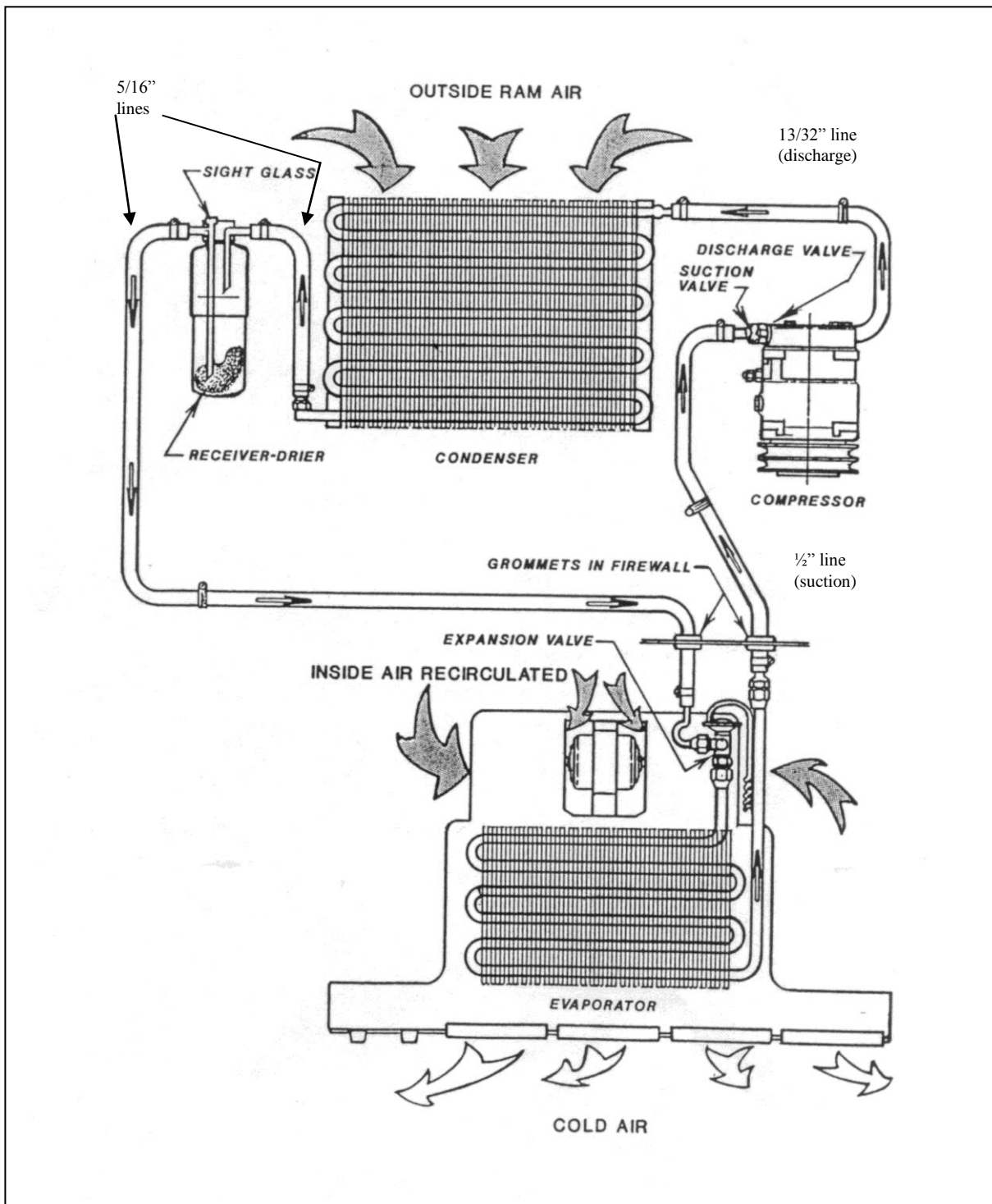

## Thermostat Setting Procedures

- 1) Thermostat types
  - a) preset
  - b) adjustable
    - a) A preset thermostat is adjusted to its specific cut in and cut out temperatures when manufactured and does not have a rotary adjustment for the operator.
    - b) An adjustable or rotary thermostat has been manufactured to a predetermined cut in and cut out temperatures, but it is also operator adjustable to achieve the desired comfort level.

Both types of thermostats can have their factory settings adjusted by turning the setting screws on the body of the thermostat. One body type has the setting screws mounted externally and labeled for direction of rotation. The other body type requires the removal of the plastic end plate to expose the set screw.

- 2) Thermostat probe location: The location of the thermostat probe in an evaporator coil can be very important to achieve the maximum cooling potential of the coil while also preventing coil freeze-up. There is no set location for the thermostat probe to be put that will be optimum for all systems, but several rules of thumb may be followed:
  - a) Insert the probe in the coldest area of the evaporator coil.
  - b) Insert the probe from the top of the coil down, if possible.
  - c) Make sure that at least the last 3" of the thermostat probe are in the coil.

To find the most likely area where the coil is the coldest, consider these factors:

- 1) Direction of air flow through the coil.
  - 2) The coil area likely to have the lowest air flow.
  - 3) The inlet locations of the refrigerant into the coil.
  - 4) The inlet of the hotter outside air into the coil area.
- 
- 1) Usually the coldest side of the evaporator coil will be the air outlet side. Often the thermostat probe can be inserted between the last and second last row of tubes.
  - 2) The lower air flow area of the evaporator coil in most systems tends to be near either end of the coil. These areas will be colder
  - 3) The area of the coil that the refrigerant inlet tube(s) occupy should be the coldest part of the coil.
  - 4) If the system is equipped with an outside air intake, where and how that air is brought into the evaporator area can have a large effect on the coil temperature. If all the outside air is piped into the evaporator in one area, that area will be considerably warmer in hot weather.

By looking at all these different factors, the area of an evaporator coil most likely to be the coldest can be determined.

Once the probe is inserted, the A/C system needs to be tested. Run the system to ensure that the thermostat is cycling the compressor off at the appropriate temperature. A core temperature ranging between 25° and 30° F should cause the thermostat to cycle off. The air temperature at the vent outlet closest to the evaporator coil should be between 38° F and 45° F when the compressor cycles off.

If the thermostat doesn't cycle off after a reasonable cool down period, and the air outlet temperature has dropped below 40° F, the cut in and cut out settings should be adjusted until the compressor is cycling on and off regularly. Let the system run for a decent time period (at least 15 min) and then check the evaporator coil for any signs of freezing.



## Aeroquip E-Z Clip Assembly Instructions

Step 1. Cut the hose to proper length with an appropriate cutting tool. Aeroquip's hand held hose cutter has been specially designed for cutting all non-wire reinforced hose, such as GH-134 Multi-Refrigerant hose. Be sure the cut is made square to the hose length.

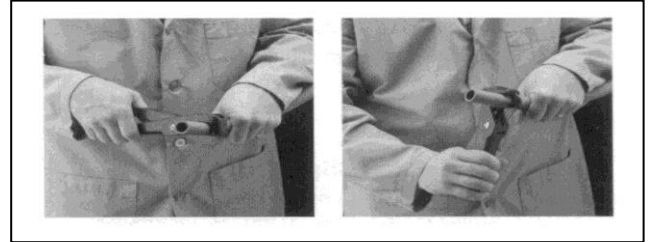

Step 2. Install two proper-sized clips onto the cut end of the hose. Orientation of the clips does not affect the performance of the connection. However, for ease of assembly, both clips should have the same orientation. NOTE: Failure to slide the clips over the hose at this time will require the clips to be stretched over the hose or fitting later. This may permanently damage the clip.

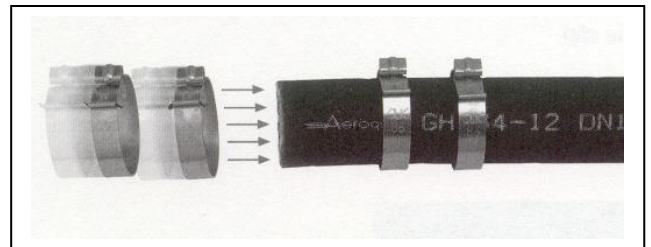

Step 3. Lubricate the nipple with a generous amount of the refrigeration or A/C system's compressor lubricating oil. This MUST be done to lower the force of nipple insertion.

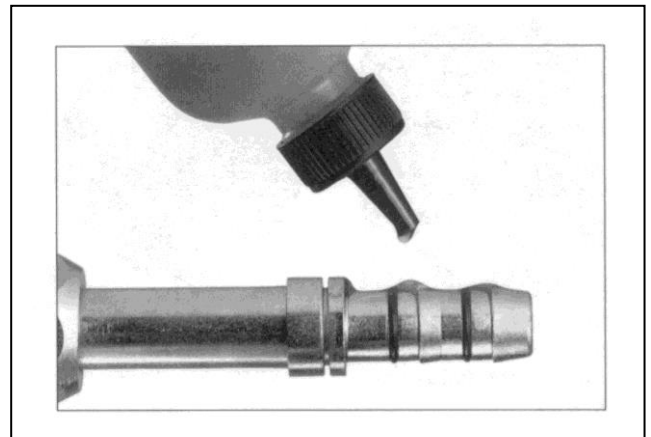

Step 4. Insert the nipple into the hose. To ensure that the nipple is fully inserted, check the gap between the cut end of the hose and the shoulder on the nipple. Care should be taken to avoid kinking or other damage to the hose during nipple insertion. NOTE: Be sure to wipe excess oil from the nipple and hose.



Step 5. Snap the cage into the groove on the nipple. The arms should extend over the hose length. When the cage has been correctly installed in the cage groove, the cage will be able to rotate in the groove. This step **MUST** be performed to ensure:

1. The clips will be located over the O-rings on the nipple.
2. The connection will be compatible with the connection's pressure rating.

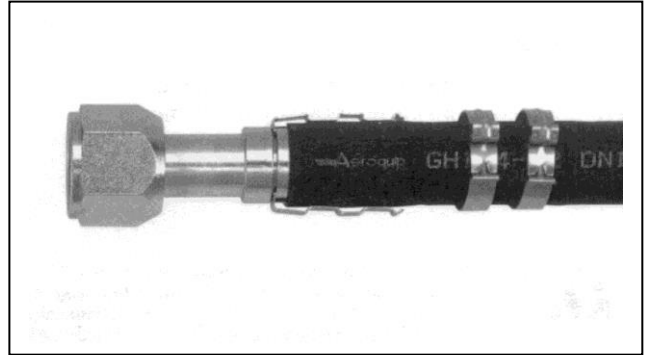

Step 6. Slide the clips over the cage arms and into the channels on each arm.

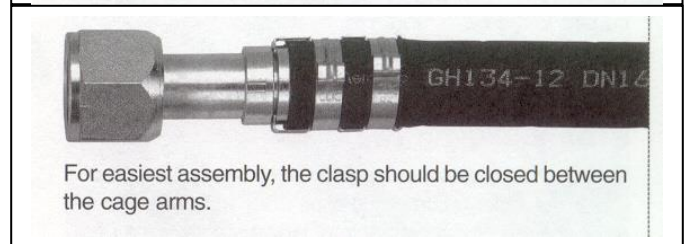

Step 7. Use the pliers to close the clips. The pliers should be positioned squarely on the clip connection points and should remain square during the closing of the clip.

**NOTICE:** E-Z Clip components should not be reused.

